

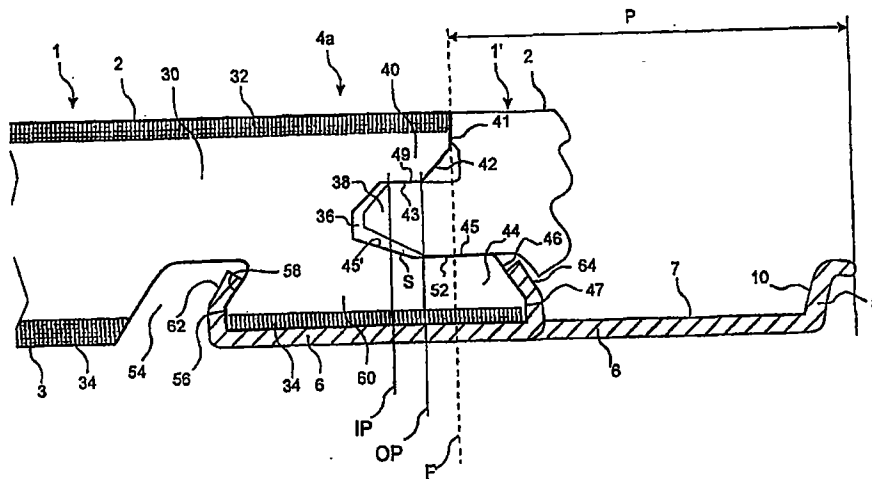

INTERNATIONAL APPLICATION PUBLISHED UNDER THE PATENT COOPERATION TREATY (PCT)

(51) International Patent Classification ⁶ : E04F 15/04	A1	(11) International Publication Number: WO 99/66151
		(43) International Publication Date: 23 December 1999 (23.12.99)
<p>(21) International Application Number: PCT/SE99/00933</p> <p>(22) International Filing Date: 31 May 1999 (31.05.99)</p> <p>(30) Priority Data: 9801987-0 3 June 1998 (03.06.98) SE</p> <p>(71) Applicant (for all designated States except US): VÄLINGE ALUMINIUM AB [SE/SE]; Kyrkogränd 1, S-260 40 Viken (SE).</p> <p>(72) Inventor; and (75) Inventor/Applicant (for US only): PERVAN, Darko [SE/SE]; Kyrkogränd 1, S-260 40 Viken (SE).</p> <p>(74) Agent: AWAPATENT AB; P.O. Box 5117, S-200 71 Malmö (SE).</p>	<p>(81) Designated States: AE, AL, AM, AT, AT (Utility model), AU, AZ, BA, BB, BG, BR, BY, CA, CH, CN, CU, CZ, CZ (Utility model), DE, DE (Utility model), DK, DK (Utility model), EE, EE (Utility model), ES, FI, FI (Utility model), GB, GD, GE, GH, GM, HR, HU, ID, IL, IN, IS, JP, KE, KG, KP, KR, KZ, LC, LK, LR, LS, LT, LU, LV, MD, MG, MK, MN, MW, MX, NO, NZ, PL, PT, RO, RU, SD, SE, SG, SI, SK, SK (Utility model), SL, TJ, TM, TR, TT, UA, UG, US, UZ, VN, YU, ZA, ZW, ARIPO patent (GH, GM, KE, LS, MW, SD, SL, SZ, UG, ZW), Eurasian patent (AM, AZ, BY, KG, KZ, MD, RU, TJ, TM), European patent (AT, BE, CH, CY, DE, DK, ES, FI, FR, GB, GR, IE, IT, LU, MC, NL, PT, SE), OAPI patent (BF, BJ, CF, CG, CI, CM, GA, GN, GW, ML, MR, NE, SN, TD, TG).</p> <p>Published With international search report. Before the expiration of the time limit for amending the claims and to be republished in the event of the receipt of amendments. In English translation (filed in Swedish).</p>	

(54) Title: LOCKING SYSTEM AND FLOORING BOARD



(57) Abstract

The invention relates to a locking system for mechanical joining of floorboards (1, 1'). For horizontal mechanical joining there is a projecting portion (P) with a locking element (8) which cooperates with a locking groove (14) in an adjacent board (1'). A tongue-and-groove joint (36, 38) for vertical mechanical joining has cooperating upper abutment surfaces (43, 49) and cooperating lower abutment surfaces (45, 52) which are essentially parallel with the principal plane of the floorboards (1) and of which the lower abutment surfaces (45, 52) are positioned essentially outside the outer vertical plane (OP), i.e. displaced relative to the upper abutment surfaces. The tongue (38) is movable at an angle into the groove (36) and the locking element (8) is insertable into the locking groove (14) by mutual angular movement of the boards (1, 1') about the joint edges (4a, 4b). In the joined state, the cooperating upper abutment surfaces (43, 49) are limited horizontally inwards from the joint edge and outwards to the joint edge by an inner vertical plane (IP) and an outer vertical plane (OP), respectively. In the joined state there is between said vertical planes (IP, OP) and under the tongue (38) a space (S), which extends horizontally from the inner vertical plane (IP) and at least halfway to the outer vertical plane (OP). Such a space can also be formed during a final phase of the inwards angling.

FOR THE PURPOSES OF INFORMATION ONLY

Codes used to identify States party to the PCT on the front pages of pamphlets publishing international applications under the PCT.

AL	Albania	ES	Spain	LS	Lesotho	SI	Slovenia
AM	Armenia	FI	Finland	LT	Lithuania	SK	Slovakia
AT	Austria	FR	France	LU	Luxembourg	SN	Senegal
AU	Australia	GA	Gabon	LV	Latvia	SZ	Swaziland
AZ	Azerbaijan	GB	United Kingdom	MC	Monaco	TD	Chad
BA	Bosnia and Herzegovina	GE	Georgia	MD	Republic of Moldova	TG	Togo
BB	Barbados	GH	Ghana	MG	Madagascar	TJ	Tajikistan
BE	Belgium	GN	Guinea	MK	The former Yugoslav Republic of Macedonia	TM	Turkmenistan
BF	Burkina Faso	GR	Greece			TR	Turkey
BG	Bulgaria	HU	Hungary	ML	Mali	TT	Trinidad and Tobago
BJ	Benin	IE	Ireland	MN	Mongolia	UA	Ukraine
BR	Brazil	IL	Israel	MR	Mauritania	UG	Uganda
BY	Belarus	IS	Iceland	MW	Malawi	US	United States of America
CA	Canada	IT	Italy	MX	Mexico	UZ	Uzbekistan
CF	Central African Republic	JP	Japan	NE	Niger	VN	Viet Nam
CG	Congo	KE	Kenya	NL	Netherlands	YU	Yugoslavia
CH	Switzerland	KG	Kyrgyzstan	NO	Norway	ZW	Zimbabwe
CI	Côte d'Ivoire	KP	Democratic People's Republic of Korea	NZ	New Zealand		
CM	Cameroon			PL	Poland		
CN	China	KR	Republic of Korea	PT	Portugal		
CU	Cuba	KZ	Kazakstan	RO	Romania		
CZ	Czech Republic	LC	Saint Lucia	RU	Russian Federation		
DE	Germany	LI	Liechtenstein	SD	Sudan		
DK	Denmark	LK	Sri Lanka	SE	Sweden		
EE	Estonia	LR	Liberia	SG	Singapore		

LOCKING SYSTEM AND FLOORING BOARDField of the Invention

The invention generally relates to a locking system for mechanically joining floorboards. More specifically, the invention concerns an improvement of a locking system of the type described and shown in WO 94/26999. The invention also concerns a floorboard provided with such a locking system.

It is known that board material can be joined mechanically and that there are many different types of joining systems. The present invention suggests specifically how a modified tongue-and-groove joint for vertical locking and a joint for horizontal locking can be designed in an optimal manner for both function and cost level to be better than in prior-art designs.

The invention is particularly suited for mechanical joining of thin floating floorboards, such as laminate flooring and parquet flooring, and therefore the following description of prior art and the objects and features of the invention will be directed to this field of application, above all rectangular floorboards which have a wood fibre core having a size of about 1.2 * 0.2 m and a thickness of about 7 mm and which are intended to be joined along long sides as well as short sides.

Background Art

Conventional floorboards are usually joined by means of glued tongue-and-groove joints along their long sides and short sides. In laying, the boards are moved together horizontally, a projecting tongue along the joint edge of a first board being inserted into the groove along the joint edge of a second board. The same method is used for long sides as well as short sides. The tongue and groove are designed merely for such horizontal joining and with special regard to the design of glue pockets and glue

surfaces to enable efficient adhesion of the tongue in the groove. The tongue-and-groove joint has cooperating upper and lower abutment surfaces which position the boards vertically to obtain a planar upper surface of the
5 completed floor.

In addition to such conventional floorings that are joined by means of glued tongue-and-groove joints, floorboards have recently been developed which instead are mechanically joined and which do not require the use of
10 glue.

WO 94/26999 discloses a locking system for mechanical joining of building boards, especially floorboards. The boards can be locked by means of this locking system both perpendicular to and in parallel with the principal
15 plane of the boards on long sides as well as short sides. Methods for making such floorboards are disclosed in SE 9604484-7 and SE 9604483-9. The basic principles of designing and laying the floorboards as well as the methods for making the same that are described in the
20 above three documents are applicable also to the present invention, and therefore the contents of these documents are incorporated by reference in the present description.

With a view to facilitating the understanding and the description of the present invention, and the understanding of the problems behind the invention, a brief
25 description of floorboards according to WO 94/26999 follows, reference being made to Figs 1-3. This description of the prior-art technique will in applicable parts also be considered to apply to the following description of
30 embodiments of the present invention.

A floorboard 1 of known design is illustrated from below and from above in Figs 3a and 3b, respectively. The board is rectangular with a top side 2, an underside 3, two opposite long sides 4a, 4b which form joint edges,
35 and two opposite short sides 5a, 5b which form joint edges.

Both the long sides 4a, 4b and the short sides 5a, 5b can be joined mechanically without any glue in the direction D2 in Fig. 1c. To this end, the board 1 has a planar strip 6 which is mounted at the factory and which extends along one long side 4a, said strip extending along the entire long side 4a and being made of a flexible, resilient aluminium sheet. The strip 6 can be mechanically fixed according to the embodiment illustrated, or fixed by means of glue or in some other fashion. Other strip materials can be used, such as sheet of some other metal, and aluminium or plastic sections. Alternatively, the strip 6 can be integrally formed with the board 1, for example by some suitable working of the body of the board 1. However the strip 6 is always integrated with the board 1, i.e. it is not mounted on the board 1 in connection with laying. The width of the strip 6 can be about 30 mm and its thickness about 0.5 mm. A similar, although shorter strip 6' is arranged also along one short side 5a of the board 1. The edge side of the strip 4 facing away from the joint edge 4a is formed with a locking element 8 extending along the entire strip 6. The locking element 8 has an active locking surface 10 facing the joint edge 4a and having a height of, for instance, 0.5 mm. In connection with laying, the locking element 8 cooperates with a locking groove 14, which is formed in the underside 3 of the opposite long side 4b of an adjacent board 1'. The short side strip 6' is provided with a corresponding locking element 8' and the opposite short side 5b has a corresponding locking groove 14'.

For mechanical joining of long sides as well as short sides also in the vertical direction (direction D1 in Fig. 1c), the board 1 is also formed, along one long side 4a and one short side 5a, with a laterally open recess 16. The recess 16 is defined downwards by the associated strips 6, 6'. At the opposite edges 4b and 5b there is an upper recess 18 defining a locking tongue cooperating with the recess 16 (see Fig. 2a).

Figs 1a-1c show how two such boards 1, 1' can be joined by downwards angling. Figs 2a-2c show how the boards 1, 1' can instead be joined by snap action. The long sides 4a, 4b can be joined by both methods, whereas the short sides 5a, 5b - after laying of the first row - are normally joined after joining of the long sides, and merely by snap action. When a new board 1' and a previously laid board 1 are to be joined along their long sides according to Figs 1a-1c, the long side 4b of the new board 1' is pressed against the long side 4a of the previously laid board 1 according to Fig. 1a, so that the locking tongue 20 is inserted into the recess 16. The board 1' is then angled downwards to the subfloor 12 according to Fig. 1b. Now the locking tongue 20 completely enters the recess 16 while at the same time the locking element 8 of the strip 6 enters the locking groove 14. During this downwards angling, the upper part of the locking element 8 can be active and accomplish a guiding of the new board 1' towards the previously laid board 1. In the joined state according to Fig. 1c, the boards 1, 1' are locked in both D1 direction and D2 direction, but can be displaced relative to each other in the longitudinal direction of the joint.

Figs 2a-2c illustrate how also the short sides 5a and 5b of the boards 1, 1' can be mechanically joined in both D1 and D2 direction by the new board 1' being moved essentially horizontally towards the previously laid board 1. This can be carried out after the long side 4b of the new board 1' has been joined as described above. In the first step in Fig. 2a, bevelled surfaces adjacent to the recess 16 and the locking tongue 20 cooperate so that the strip 6' is forced downwards as a direct consequence of the joining of the short sides 5a, 5b. During the final joining, the strip 6' snaps upwards as the locking element 8' enters the locking groove 14'. By repeating the operations shown in Figs 1 and 2, the laying of the entire floor can be made without glue and

along all joint edges. Thus, prior-art floorboards of the above-mentioned type are mechanically joined by, as a rule, first being angled downwards on the long side, and when the long side is locked, the short sides are snapped together by horizontal displacement along the long side. The boards 1, 1' can be taken up again in reverse order, without damaging the joint, and be laid once more.

In order to function optimally, the boards, after being joined, should along their long sides be able to take a position where there is a possibility of a small play between the locking surface 10 and the locking groove 14. For a more detailed description of this play, reference is made to WO 94/26999.

In addition to the disclosure of the above-mentioned patent specifications, Norske Skog Flooring AS (licensee of Välinge Aluminium AB) introduced a laminate flooring with a mechanical joining system according to WO 94/26999 in January 1996 in connection with the Domotex fair in Hannover, Germany. This laminate flooring marketed under the trademark Alloc[®] is 7.6 mm thick, has a 0.6 mm aluminium strip 6 which is mechanically fixed on the tongue side and the active locking surface 10 of the locking element 8 has an inclination of about 80° to the plane of the board. The vertical joint is formed as a modified tongue-and-groove joint, where the term "modified" relates to the possibility of joining groove and tongue by inwards angling.

WO 97/47834 (Unilin) discloses a mechanical joining system which is essentially based on the above prior-art principles. In the corresponding product which this applicant has begun to market in the latter part of 1997, biasing between the boards is strived for. This leads to high friction and difficulties in angling together and displacing the boards. The document shows a plurality of embodiments of the locking system.

Other prior-art locking systems for mechanical joining of board material are disclosed in GB 2,256,023,

which shows one-sided mechanical joining for the provision of an expansion joint, and in US 4,426,820, which shows a mechanical locking system which, however, does not allow displacement and locking of short sides by snap
5 action.

Summary of the Invention

Although the flooring according to WO 94/26999 and the flooring marketed under the trademark Alloc[®] have
10 great advantages compared with conventional, glued floors, additional improvements are desirable. There are today no known products or methods which result in sufficiently good solutions to the problems, requirements and desiderata stated below and related to (i) manufacture
15 of floorboards with mechanical locking systems of the type stated, (ii) handling and laying of such floorboards, and (iii) properties of a finished, joined floor prepared from such floorboards.

20 (i) Manufacture

In connection with the manufacture of the floorboards, the following problems, requirements and desiderata exist:

1. It is known that angling-together of the floorboards
25 can be carried out with a tongue whose lower front part follows a circular arc. If this lower front part of the tongue should constitute a lower abutment surface against the groove in the joined state, the lower abutment surface of the groove must be
30 made with a corresponding arcuate shape to fit the tongue in the locked position. This solution suffers from the drawback that it requires the making of arcuate surfaces and, consequently, a very accurate adjustment of the wood-working tools both vertically
35 and horizontally.
2. From the viewpoint of manufacture it is desirable for the abutment surfaces of the groove which are

to cooperate with the abutment surfaces of the tongue to be planar and parallel with the floor surface since narrow tolerances for the abutment surfaces of the tongue-and-groove joint (a few hundredth parts of a mm) can then be obtained without a critical horizontal adjustment of the wood-working tools being necessary for the forming of tongue and groove.

- 5
10
15
20
25
30
3. The manufacture is facilitated if there are as many degrees of freedom as possible in respect of tolerances of manufacture. It is therefore desirable that the number of critical abutment and guide surfaces be limited as much as possible without lowering the standards of perfect quality in the joined state with small joint gaps and limited vertical difference (in the order of 0.1 mm) and excellent function in the angling upwards and downwards in connection with laying and removal.
4. To make it possible to form the groove by means of horizontally operating wood-working tools in the case where the projecting portion is made in one piece with the body of the board, it is a great advantage if the locking element of the projecting portion is positioned under the lower abutment surface of the groove or on a level therewith. The working tools can then be inserted horizontally towards the joint edge above the locking element.
5. To achieve less waste of material when machining the boards for making the locking system, it is advantageous if the tongue projects to a minimum extent in the horizontal direction outside the joint edge. The bigger the tongue, the more material must be removed above and below the tongue.

(ii) Handling/Laying

In connection with handling and laying of the floorboards, the following problems, requirements and desiderata exist:

- 5 1. It must be possible to join the long sides of the boards by angling together about the upper joint edges of the boards. In the angling together, it must be possible to insert the tongue in the groove, which necessitates a modification of the design of conventional, glued tongue-and-groove joints which
10 only need to be pushed together horizontally.
2. It should be possible to carry out the inwards angling so that the vertical fit between tongue and groove can occur with maximum accuracy or tolerance
15 to obtain good vertical locking of the completed floor. With prior-art tongue-and-groove joints it is difficult to satisfy such a requirement for a good fit in the joined state and at the same time achieve an optimal function in the inwards angling.
- 20 3. For easy laying without any undesired resistance, it is at the same time a wish that the tongue need not be pressed or forced into the groove during the angling movement.
4. Known mechanical locking systems suffer from drawbacks relating to the undesired possibility of backwards angling, i.e. the possibility of turning two
25 joined boards relative to each other and downwards about the joint edge, i.e. past the horizontal position. In the above prior-art flooring in Figs 1-3, it is only the rigidity of the aluminium strip that restricts the possibility of backwards angling. When
30 a user handles the boards it would be advantageous if backwards angling was made difficult or could be prevented since it would then not be possible for consumers to open the boards in an incorrect manner
35 in connection with testing and thus damage or bend the projecting portion, i.e. the aluminium strip in

Figs 1-3. A solution where the strip is made more rigid is in opposition to the requirement that the strip must be bendable and resilient to achieve a good snap-in function.

- 5 5. If it should also be possible to take up the locking system, generally the same requirements and desiderata for upwards angling are applicable as for downwards angling.

10 (iii) Properties of the Joined Floor

For the completed, joined floor the following problems, requirements and desiderata exist:

- 15 1. With a view to preventing undesirable vertical displacement between the joint edges of the boards of the completed floor, there should be a close vertical fit between tongue and groove.
- 20 2. Curved abutment surfaces constitute a disadvantage not only from the viewpoint of manufacture. A high horizontal tension load on the joint, which may arise especially owing to shrinkage at low relative humidity, can in combination with curved abutment surfaces of the tongue-and-groove joint cause undesirable vertical displacement and/or undesirable vertical play if the tension load causes the boards to slide away somewhat from each other. It is therefore desirable for the abutment surfaces of the groove that are to cooperate with the abutment surfaces of the tongue to be planar and parallel with the floor surface.
- 25 3. Also for the completed floor it is preferable to counteract or prevent backwards angling of the floorboards about the joint edges. When a completed floor swells in summer, it is possible - if the possibility of backwards angling is prevented - to counteract rising of the floorboards. This is particularly important for large floors with a considerable degree of load and swelling.
- 30
- 35

4. The depth of the groove should be minimised since drying in winter may cause what is referred to as edge rising if the groove is weakened by being mill-
ed out to a great extent, i.e. by having a great
5 depth. This wish for a limited depth of the groove is particularly important for mechanically joined floors where the edges are not held together by means of glue.

10 Known vertical and horizontal joints for mechanical-ly joined floorboards do not satisfy the above-identified requirements, problems and desiderata and are therefore not optimal in respect of function and production cost.

The general problem and the object of the invention
15 thus are to provide a mechanical locking system of the type described above, which permits inwards angling from above, which counteracts backwards angling and which yields an exact fit between tongue and groove, while at the same time the manufacture can be optimised in respect
20 of accuracy, number of critical parameters and costs of material.

Summing up, there is a great demand for providing a locking system of the type stated above which to a greater extent than prior art takes the above-mentioned
25 requirements, problems and desiderata in consideration. An object of the invention is to satisfy this demand.

These and other objects of the invention are achieved by a locking system and a floorboard which have the features stated in the independent claims, preferred
30 embodiments being defined in the dependent claims.

The invention is based on the understanding that with prior-art locking systems it is difficult to solve all the above problems and desiderata at the same time, which means that a modification of the locking systems
35 is necessary. The invention is specifically based on the understanding that essentially all the above-mentioned requirements, problems and desiderata can be satisfied

if the known tongue-and-groove joint is modified in a special manner. When developing mechanical locking systems, one has traditionally started from the design of the glued tongue-and-groove joint. From this starting point, the known vertical joint has then been supplemented with a horizontal lock and the tongue-and-groove joint has been modified so that inwards angling can more easily be carried out from above. However, what has not been taken into consideration in this development is that in a mechanical system it is not necessary to be able to glue tongue and groove together in an efficient way. Since gluing is not necessary, there is free scope for modifications of the known tongue-and-groove joint. Free scope for modifications is also allowed by the fact that known glued tongue-and-groove joints also serve to ensure horizontal joining (by means of glue), which requirement does not exist in mechanical locking systems of the type to which the invention is directed.

According to a first aspect of the invention, a locking system is provided for mechanical joining of floorboards, said locking system comprising a tongue-and-groove joint, the groove and tongue of which have cooperating upper abutment surfaces and cooperating lower abutment surfaces for vertical locking of two joint edges of two adjacent floorboards, said upper and lower abutment surfaces being essentially parallel with the principal plane of the floorboards, and said locking system comprising, for horizontal mechanical joining of the joint edges perpendicular to the same, a locking groove formed in the underside of a first one of the joint edges and extended in parallel therewith, and a portion projecting from the second joint edge and integrated with a body of the floorboard, said portion supporting, at a distance from the joint edge, a locking element cooperating with the locking groove, wherein said tongue is angleable into the groove, and wherein said locking element is insertable into the locking groove by a mutual angular

motion of the boards about the joint edges. The locking system according to the invention is characterised in

that, in the joined state, the cooperating upper abutment surfaces are limited horizontally inwards from the joint edge and horizontally outwards to the joint edge by an inner vertical plane and an outer vertical plane, respectively;

that the tongue-and-groove joint is so designed that there is in the groove, in the joined state, between the inner vertical plane and the outer vertical plane and below the tongue, a space which extends horizontally from the inner vertical plane and at least halfway to the outer vertical plane;

that the tongue-and-groove joint is further so designed that the boards, during a final phase of the inwards angling when the locking element is inserted into the locking groove, can take a position where there is a space in the groove between the inner and the outer vertical plane and below the tongue; and

that the lower abutment surfaces are positioned essentially outside the outer vertical plane.

By the expression "cooperating abutment surfaces" is meant surfaces of tongue and groove which in the joined state of the floorboards either engage each other directly in the vertical direction or at least are in such immediate vicinity of each other in the vertical direction that they can be made to contact each other to prevent the boards from being relatively offset in the vertical direction. Thus, within the scope of the invention there can especially be horizontal surfaces of both the tongue and the groove which do not form any "cooperating abutment surface", but which can have some other specific function.

In a conventional tongue-and-groove joint, both upper and lower abutment surfaces are, as a rule, located in the inner part of the groove. With planar abutment surfaces in the inner part of the groove, it is not pos-

sible to achieve a good fit as well as optimal inwards angling. If tongue and groove are equilaterally designed on the upper and lower side, the floorboards are just as easy to angle upwards as downwards/backwards.

5 A locking system according to the invention, however, can exhibit, both during the final inwards angling and in the joined state, a space in the groove under the tongue. Thanks to this space, the tongue can unimpededly be angled into the groove when two boards are joined by
10 being angled together. Moreover, the locking system can be so designed that the angling together can take place while the boards are held in mutual contact at the upper corner portions of the adjacent joint edges. Despite the provision of this space in the groove under the tongue,
15 it is according to the invention possible to achieve an exact vertical fit between tongue and groove in the joined state thanks to the fact that the lower abutment surfaces are, at least in large part, horizontally displaced outside the upper abutment surfaces.

20 The present invention solves, at the same time, the problem of undesirable backwards angling of the boards thanks to the lower abutment surfaces being displaced relative to the upper abutment surfaces in the direction of the locking element. In the known locking systems,
25 it is only the rigidity of the projecting portion that limits the backwards angling. In the invention, however, said displacement accomplishes an angular limitation of the movement of the tongue that effectively counteracts any angling of the tongue past its intended position in
30 the groove, i.e. that counteracts backwards angling of the boards.

The invention also presents the advantage that manufacture can be carried out with working tools which operate only in the plane of the floorboards, thanks to the
35 fact that no curved surfaces are necessary in the tongue-and-groove joint. The tolerances of the vertical fit can thus be made considerably better. The space in the groove

under the tongue thus solves not only a problem relating to inwards angling, but also solves the problem of achieving an exact vertical fit between the boards. Thus the space has a function both during the inwards angling and in the joined state.

Moreover the use of essentially plane-parallel abutment surfaces in the tongue-and-groove joint means avoiding the above-mentioned problems with vertical displacement and/or play caused by any horizontal tension load on the joint. Completely planar, horizontal surfaces are ideal, but there should be a possibility of implementing the invention with surfaces that marginally deviate from this ideal design.

To sum up, the present invention provides a locking system for mechanical joining, which permits inwards angling from above, counteracts backwards angling and yields an exact fit between tongue and groove. Inwards angling can be carried out without any vertical play between tongue and groove and without necessitating opening of the groove when the tongue is pressed in. The depth of the tongue and groove does not affect the possibility of inwards angling and the fit between tongue and groove or the relative position of the floorboards. Backwards angling is counteracted, and the groove can be manufactured rationally by means of horizontally operating tools which also permit manufacture of the locking device in a machined wood fibre strip.

In a preferred embodiment, the space in the groove under the tongue, in the joined state, is horizontally extended essentially all the way from the outer vertical plane to the inner vertical plane. Thus, in this embodiment there is in the joined state a space over essentially the entire horizontal range in the groove, within which the cooperating upper abutment surfaces are extended. In this embodiment, essentially no part of the lower abutment surfaces are positioned inside the outer vertical plane. In theory, this embodiment would be the most

ideal one since the vertical fit between tongue and groove can then be optimised while at the same time the tongue can unimpededly be inserted into the groove. However, within the scope of the invention, there is a possibility of the lower abutment surfaces extending somewhat inwards in a direction towards the bottom of the groove past the outer vertical plane.

The space under the tongue can be limited downwards by a planar, horizontal surface of the groove, whose extension to the edge joint forms the lower abutment surface of the groove, or by a groove surface which is inclined to the horizontal plane or arcuate, or a combination of a planar surface and an inclined/arcuate surface of the groove.

Generally, the space in the groove under the tongue can be formed by the tongue being bevelled/cut away, or by the groove being hollowed out.

In an embodiment which is preferred in respect of horizontal tolerances in manufacture, the groove has in the joined state an upper and a lower horizontal surface, which constitute inwardly directed extensions of the upper abutment surface and the lower abutment surface, respectively, of the groove, and there is also an inner horizontal play between the bottom of the groove and the tip of the tongue. Owing to the inwardly directed extensions of the abutment surfaces of the groove as well as the play between the groove and the tongue at the bottom of the groove, working of tongue and groove in the horizontal direction can be carried out without strict tolerance requirements in the horizontal direction while at the same time it is possible to ensure both an exact vertical fit of the boards and unimpeded inwards angling.

According to the invention, the projecting portion is integrated with a body of the board. The term "integrated" should be considered to comprise (i) cases where the projecting portion is made of a separate component integrally connected with the body at the factory, (ii)

cases where the projecting portion is formed in one piece with the body, and (iii) a combination of (i) and (ii), i.e. cases where the inner part of the projecting portion is formed in one piece with the body and its outer part consists of a separate factory-mounted component.

According to a second aspect of the invention, a floorboard is provided, having a locking system according to the invention, on at least two opposite sides and preferably on all four sides to permit joining of all sides of the floorboards.

These and other advantages of the invention and preferred embodiments will appear from the following description and are defined in the appended claims.

Different aspects of the invention will now be described in more detail by way of examples with reference to the accompanying drawings. Those parts of the inventive board which have equivalents in the prior-art board in Figs 1-3 are provided with the same reference numerals.

20

Brief Description of the Drawings

Figs 1a-c show in three steps a downwards angling method for mechanical joining of long sides of floorboards according to WO 94/026999.

Figs 2a-c show in three steps a snap-in method for mechanical joining of short sides of floorboards according to WO 94/26999.

Figs 3a and 3b illustrate a floorboard according to WO 94/26999 seen from above and from below, respectively.

Fig. 4 shows a floorboard with a locking system according to a first embodiment of the invention, an adjacent floorboard being broken away.

Fig. 5 is a top plan view of a floorboard according to Fig. 4.

Fig. 6a shows on a larger scale a broken-away corner portion C1 of the board in Fig. 5, and Figs 6b and 6c illustrate vertical sections of the joint edges along

the long side 4a and the short side 5a of the board in Fig. 5, from which it specifically appears that the long side and the short side are different.

5 Figs 7a-c illustrate a downwards angling method for mechanical joining of long sides of the floorboard according to Figs 4-6.

Figs 8a-c illustrate a snap-in method for mechanical joining of short sides of the floorboard according to Figs 4-6.

10 Fig. 9 illustrates a floorboard with a locking system according to a second embodiment of the invention.

Figs 10a and 10b illustrate on a larger scale broken away details corresponding to Fig. 9 and the importance of a space in the inner part of the groove during inwards angling and in the joined state, respectively.

15 Fig. 11 illustrates the making of the groove in the floorboard in Fig. 9.

Description of Preferred Embodiments

20 A first preferred embodiment of a floorboard 1 provided with a locking system according to the invention will now be described with reference to Figs 4-7. Fig. 4 is a sectional view of a long side 4a of the board 1, and also part of a long side 4b of an adjacent board 1.

25 The body of the board 1 consists of a core 30 of, for instance, wood fibre, which supports a top laminate 32 on its front side and a balance layer 34 on its rear side. The board body 30-34 is rectangular with long sides 4a, 4b and short sides 5a, 5b. A separate strip 6 with a

30 formed locking element 8 is mounted at the factory on the body 30-34, so that the strip 6 constitutes an integrated part of the completed floorboard 1. In the Example shown, the strip 6 is made of resilient aluminium sheet. As an illustrative, non-limiting example, the aluminium sheet

35 can have a thickness in the order of 0.6 mm and the floorboard a thickness in the order of 7 mm. For additional description of dimensions, possible materials,

etc. for the strip 6, reference is made to the above description of the prior-art board.

The strip 6 is formed with a locking element 8, whose active locking surface 10 cooperates with a locking groove 14 in the opposite joint edge 4b of the adjacent board 1' for horizontal interlocking of the boards 1, 1' transversely of the joint edge (D2).

For the forming of a vertical lock in the D1 direction, the joint edge 4a has a laterally open groove 36 and the opposite joint edge 4b has a laterally projecting tongue 38 (corresponding to the locking tongue 20), which in the joined state is received in the groove 36. The free surface of the upper part 40 of the groove 36 has a vertical upper portion 41, a bevelled portion 42 and an upper planar, horizontal abutment surface 43 for the tongue 38. The free surface of the lower part 44 of the groove 36 has a lower inclined surface 45', a lower planar, horizontal abutment surface 45 for the tongue 38, a bevelled portion 46 and a lower vertical portion 47. The opposite joint edge 4b (see Fig. 7a) has an upper vertical portion 48, and the tongue 38 has an upper planar, horizontal abutment surface 49, an upper bevelled portion 50, a lower bevelled portion 51 and a lower planar, horizontal abutment surface 52. In the joined state according to Figs 4, 7c and 8c, the boards 1, 1' are locked relative to each other in the vertical direction D1. An upwards movement of the board 1' is counteracted by engagement between the upper abutment surfaces 43 and 49 while a downwards movement of the board 1' is counteracted on the one hand by engagement between the lower abutment surfaces 45 and 52 and, on the other hand, by the board 1' resting on a lower surface portion 7 of the strip 6.

In the joined state, the two juxtaposed upper portions 41 and 48 define a vertical joint plane F. In the Figures, an inner vertical plane IP and an outer vertical plane OP are indicated. The inner vertical plane IP

is defined by the inner boundary line of the upper abutment surfaces 43, 49 while the outer vertical plane OP is defined by the outer boundary line of the upper abutment surfaces 43, 49.

5 As is evident from Fig. 4, the lower part 44 of the groove 36 is extended a distance outside the joint plane F. The lower planar, horizontal abutment surface 45 of the groove 36 thus is positioned partially inside and partially outside the joint plane F while the upper abutment surface 43 of the groove 36 is positioned completely
10 inside and at a distance from the joint plane F. More specifically, the upper abutment surface 43 of the groove 36 is in its entirety positioned between the vertical planes IP and OP while the lower abutment surface 45 of
15 the groove 36 is in its entirety positioned outside the vertical plane OP and extends partially outside the joint plane F. The significance of these circumstances will be described below.

The joint edge 4a is in its underside formed with
20 a continuous mounting groove 54 having a vertical lower gripping edge 56 and an inclined gripping edge 58. The gripping edges formed of the surfaces 46, 47, 56, 58 together define a fixing shoulder 60 for mechanical fixing of the strip 6. The fixing is carried out according
25 to the same principle as in the prior-art board and can be carried out with the methods described in the above documents. A continuous lip 62 of the strip 6 is thus bent round the gripping edges 56, 58 of the groove 54 while a plurality of punched tongues 64 are bent round
30 the surfaces 46, 47 of the projecting portion 44. The tongues 64 and the associated punched holes 65 are shown in the broken-away view in Fig. 6a.

Reference is now made to Figs 7a-c. The angling together of the long sides 4a, 4b can be carried out
35 according to the same principle as in Figs 1a-c. In this context, a small downwards bending of the strip 6 can generally be carried out - not only for this embodiment -

as shown in the laying sequence in Figs 7a-c. This downwards bending of the strip 6 together with an inclination of the locking element 8 makes it possible for the boards 1, 1' to be angled downwards and upwards again with very tight joint edges at the upper surfaces 41 and 48. The locking element 8 should preferably have a high guiding capability so that the boards in connection with downwards angling are pushed towards the joint edge. The locking element 8 should have a large guiding part. For optimal function, the boards, after being joined and along their long sides 4a, 4b, should be able to take a position where there is a small play between locking element and locking groove, which need not be greater than 0.02-0.05 mm. This play permits displacement and bridges width tolerances. The friction in the joint should be low.

Figs 8a-c illustrate that snapping together of the short sides 5a, 5b can be carried out according to the same principle as in Figs 2a-c. However, the locking system on the short sides in this embodiment is designed differently from the long sides and is specifically adapted for snapping in by vertical displacement and downwards bending of the strip. One difference is that the projecting portion P - here in the form of an aluminium strip 6' - on the short sides 5a, 5b is arranged on the same joint edge 5a as the tongue 38' while the locking groove 14' is formed in the same joint edge 5b as the groove 36. A further difference is that the locking element 8' on the short sides is somewhat lower than the locking element 8 on the long sides. In this embodiment, it is bevelled undersides of the tongue and groove which cooperate to obtain this vertical displacement and snapping in. Moreover, it may be particularly noted that the embodiment in Figs 8a-c in fact has double tongue-and-groove joints, one tongue and one groove on each joint edge, both joints being designed according to the invention with displaced upper and lower abutment surfaces.

Fig. 9 shows a second embodiment of a locking system according to the invention. In contrast to the embodiment in Figs 4-8, the projecting portion P is formed, by machining, in one piece with the body of the board 1. The body can be composed of the same materials as in the previous embodiment. In Fig. 9, the vertical planes IP, OP and F are also indicated according to the previous definition. Like in the preceding embodiment, the lower abutment surfaces 45, 52 are entirely displaced outside the outer vertical plane OP.

Fig. 10a shows on a larger scale how a downwards angling of the tongue 38 in the embodiment in Fig. 9 has already begun. As described above, the tongue 38 is in its lower part defined by a planar abutment surface 52 and a bevelled portion 51. The groove 36 in Fig. 9, however, is fully planar at the bottom, i.e. the planar, horizontal surface 45 extends all the way to the bottom of the groove 36. Reference numerals 52' and 51' indicate boundary lines of a prior-art tongue. As is clearly to be seen from the Figure, it would with such a known design not be possible to easily angle the tongue 38 inwards into the groove 36 since the corner portion 53 of the tongue 38 would strike against the surface 45 of the groove 36. Such a tongue would therefore have to be pressed into the groove if at all possible. Alternatively, it would be necessary to make the groove 36 higher, which would result in an undesirable play in the vertical direction.

It is evident from Fig. 10a, however, that according to the invention there may, during the inwards angling, be a space S under the tongue 38 between the vertical planes IP and OP, which permits the tongue to be inwardly angled into the groove. In this embodiment and in the illustrated angular position, this space S extends all the way between the vertical planes IP and OP.

Fig. 10b shows the embodiment in Fig. 9 in the joined state. In the area between the inner and outer verti-

cal plane IP and OP there is under the tongue 38 still a space S, which also extends all the way between IP and OP.

Fig. 11 schematically shows the making of the groove 5 35 in the embodiment in Fig. 9. A rotating working tool 80 with a cutting element 81 of, for instance, hard metal or diamond rotates about an axis A at a distance from the locking element 8. Such horizontal working by means of a tool with a relatively large diameter is possible thanks 10 to the locking element 8 being positioned on the same level or on a level under the lower abutment surface 45 of the groove 36.

In connection with the laying, the major part of the short sides is locked by snap action, as described above 15 with reference to Figs 8a-c. However, the first row is frequently laid by angling together the short sides, in the same manner as described for the long sides in connection with Figs 7a-c. When taking up the boards, the short sides can both be pulled apart along the joint and 20 be angled upwards. As a rule, upwards angling is a quicker operation. The inventive locking system should thus be designed while also taking into consideration the possibility of angling the short side.

The aspects of the invention which include a separate 25 strip can preferably be implemented in combination with use of an equalising groove of the kind described in WO 94/26999. Adjacent joint edges are equalised in the thickness direction by working of the underside, so that the upper sides of the floorboards are aligned with each 30 other when the boards have been joined. Reference E in Fig. 1a indicates that the body of the boards after such working has the same thickness in adjacent joint edges. The strip 6 is received in the groove and will thus be partly flush-mounted in the underside of the floor. A 35 corresponding arrangement can thus be realised also in combination with the invention as shown in the drawings.

CLAIMS

1. A locking system for mechanical joining of floor-
5 boards (1), said locking system comprising a tongue-and-
groove joint (36, 38), the groove (36) and tongue (38)
of which have cooperating upper abutment surfaces (43,
49) and cooperating lower abutment surfaces (45, 52) for
vertical locking of two joint edges (4a, 4b) of two adja-
10 cent floorboards (1, 1'), said upper and lower abutment
surfaces (43, 49; 45, 52) being essentially parallel with
the principal plane of the floorboards (1), and said
locking system comprising, for horizontal mechanical
joining of the joint edges (4a, 4b) perpendicular to the
15 same, a locking groove (14) formed in the underside (3)
of a first one of the joint edges (4b) and extended in
parallel therewith, and a portion (P) projecting from the
second joint edge (4a) and integrated with a body (30,
32, 34) of the floorboard (1), said portion (P) support-
20 ing, at a distance from the joint edge (4a), a locking
element (8) cooperating with the locking groove (14),
wherein said tongue (38) is anglable into the groove
(36), and wherein the locking element (8) is insertable
into the locking groove (14) by mutual angular motion
25 of the boards (1, 1') about the joint edges (4a, 4b),
c h a r a c t e r i s e d i n

that, in the joined state, the cooperating upper
abutment surfaces (43, 49) are limited horizontally
inwards from the joint edge and horizontally outwards
30 to the joint edge by an inner vertical plane (IP) and
an outer vertical plane (OP), respectively;

that the tongue-and-groove joint is so designed that
there is in the groove (45), in the joined state, between
the inner vertical plane (IP) and the outer vertical
35 plane (OP) and below the tongue (38), a space (S) which
extends horizontally from the inner vertical plane (IP)
and at least halfway to the outer vertical plane (OP);

that the tongue-and-groove joint is further so designed that the boards, during a final phase of the inwards angling when the locking element is inserted into the locking groove, can take a position where there is a space (S) in the groove (36) between the inner and the outer vertical plane (IP, OP) and below the tongue (38); and

that the lower abutment surfaces (45, 52) are positioned essentially outside the outer vertical plane (OP).

10 2. A locking system as claimed in claim 1, wherein said space (S) in the joined state is horizontally extended below the tongue (38) essentially all the way from the inner vertical plane (IP) to the outer vertical plane (OP), so that essentially no part of the lower
15 abutment surfaces (45, 52) is positioned inside the outer vertical plane (OP).

3. A locking system as claimed in claim 1 or 2, wherein said space (S) during the final phase of the inwards angling is horizontally extended below the tongue
20 (38) essentially all the way from the inner vertical plane (IP) to the outer vertical plane (OP).

4. A locking system as claimed in any one of the preceding claims, wherein the groove (36) in the joined state has an upper and a lower horizontal surface which
25 constitute inwardly directed extensions of the upper abutment surface (43) and the lower abutment surface (45), respectively, of the groove (36), and wherein there is in the joined state a horizontal play (Δ) between the bottom of the groove (36) and the tip of the tongue (38).

30 5. A locking system as claimed in any one of the preceding claims, wherein the outer vertical plane (OP) is located at a horizontal distance inside a vertical joint plane (F), which is defined by adjoining upper portions (41, 48) of the joined joint edges (4a, 4b) of the
35 two boards (1, 1').

6. A locking system as claimed in any one of the preceding claims, wherein the lower abutment surfaces

(45, 52) are located at least partially outside a vertical joint plane (F) which is defined by adjoining upper portions (41, 48) of the joined joint edges (4a, 4b) of the two boards (1, 1').

5 7. A locking system as claimed in claim 6, wherein the major part of the lower abutment surfaces (45, 52) is positioned outside the vertical joint plane (F).

10 8. A locking system as claimed in any one of the preceding claims, wherein the projecting portion (P) and the groove (36) are arranged in one and the same joint edge (4a) of the floorboard (1).

15 9. A locking system as claimed in any one of the preceding claims, wherein the projecting portion (P) is at least partially made in one piece with a body (30, 32, 34) of the floorboard (1).

20 10. A locking system as claimed in claim 9, wherein the locking element (8) of the projection portion (P) is positioned under or on a level with the lower abutment surface (45) of the groove (36).

20 11. A locking system as claimed in any one of the preceding claims, wherein the projecting portion (P) is at least partially formed of a material other than that of the body of the floorboard.

25 12. A locking system as claimed in claim 11, wherein the projecting portion (P) is at least partially formed of a separate strip (6) which is integrally connected (60, 62, 64) with the board (1) by being mounted in the factory.

30 13. A locking system as claimed in any one of the preceding claims, wherein the projecting portion (P) is resilient transversely of the principal plane of the floorboards.

35 14. A locking system as claimed in any one of the preceding claims, wherein the tongue (38) is insertable into the groove (36) and the locking element (8) is insertable into the locking groove (14) by a mutual horizontal joining of the joint edges (5a, 5b) of the boards.

15. A locking system as claimed in claim 14, wherein the groove (36) has in its upper part a bevelled portion (42) for guiding the tongue (38) into the groove (36).

5 16. A locking system as claimed in any one of the preceding claims, wherein the projecting portion (P), in the horizontal direction between the lower abutment surfaces (45, 52) of the tongue-and-groove joint on the one hand and the locking element (8) of the projecting portion (P) on the other hand, has a lower portion (7) which
10 is positioned below said lower abutment surfaces (45, 52).

17. A locking system as claimed in any one of the preceding claims, wherein the tongue (38) is anglable into the groove (36) and the locking element (8) is
15 insertable into the locking groove (14) by said mutual angular motion of the boards about upper portions (41, 48) of the joint edges (4a, 4b) while said upper portions (41, 48) are held in mutual contact.

20 18. A floorboard (1) provided along one or more sides with a locking system as claimed in any one of the preceding claims.

25 19. A floorboard (1) as claimed in claim 18, which has opposite long sides and short sides and which is mechanically joinable along its long sides with long sides of identical floorboards by downward angling and which is mechanically joinable along its short sides with short sides of identical floorboards by displacement along said long sides.

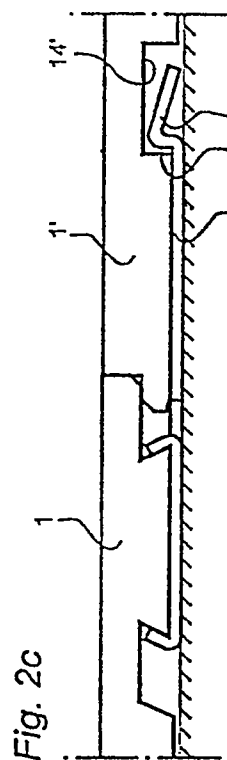
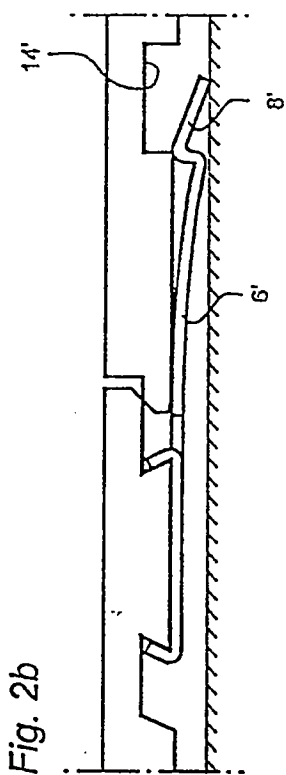
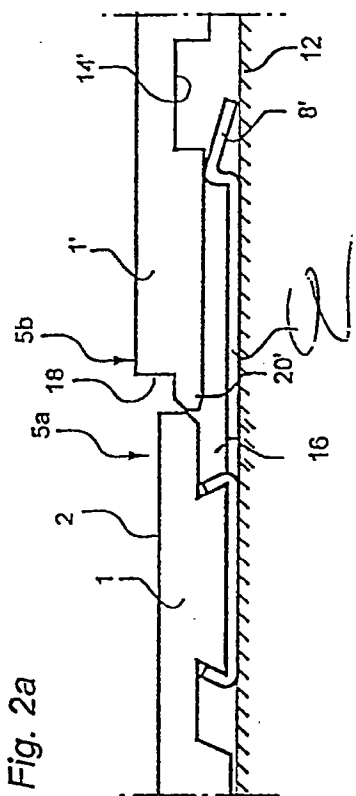

PRIOR-ART TECHNIQUE

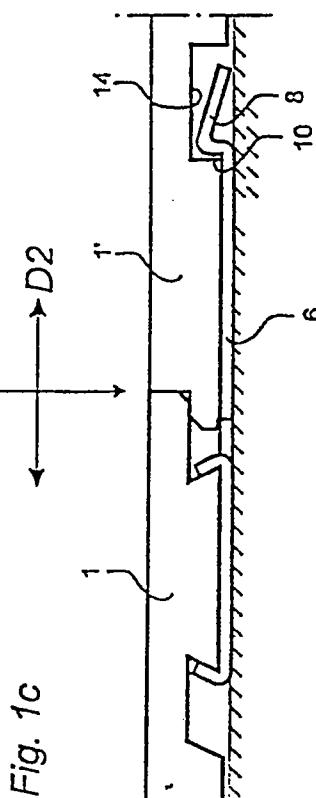
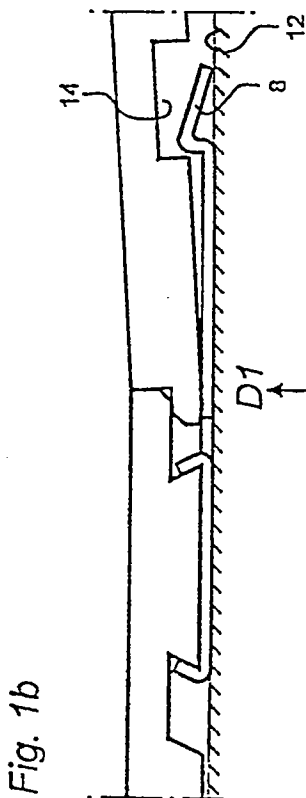
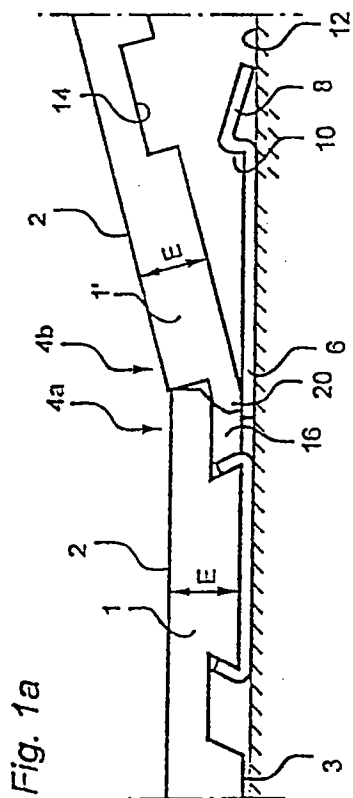

PRIOR-ART TECHNIQUE

Fig. 3a

Fig. 3b

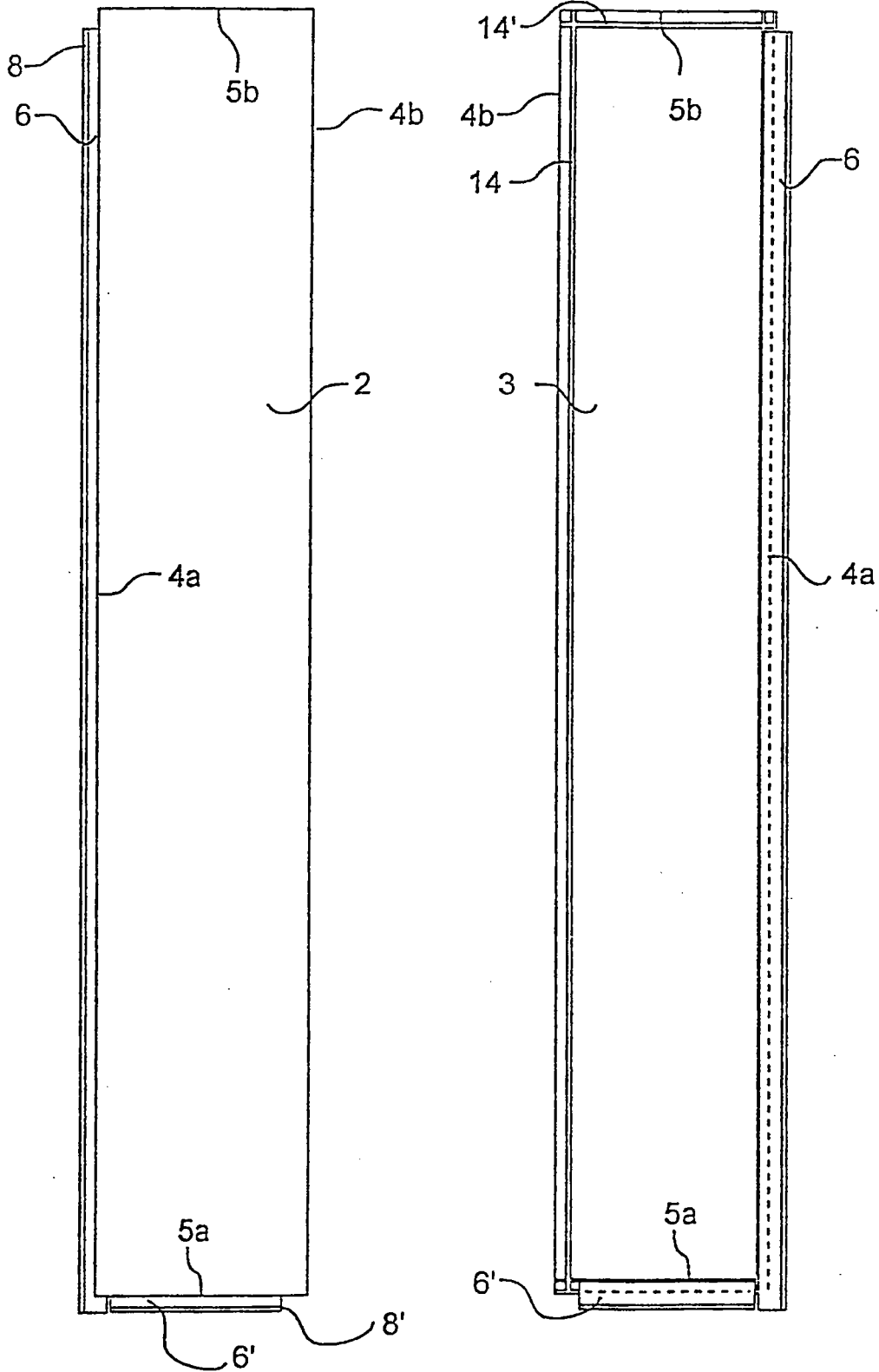

PRIOR-ART TECHNIQUE

3/8

Fig. 4

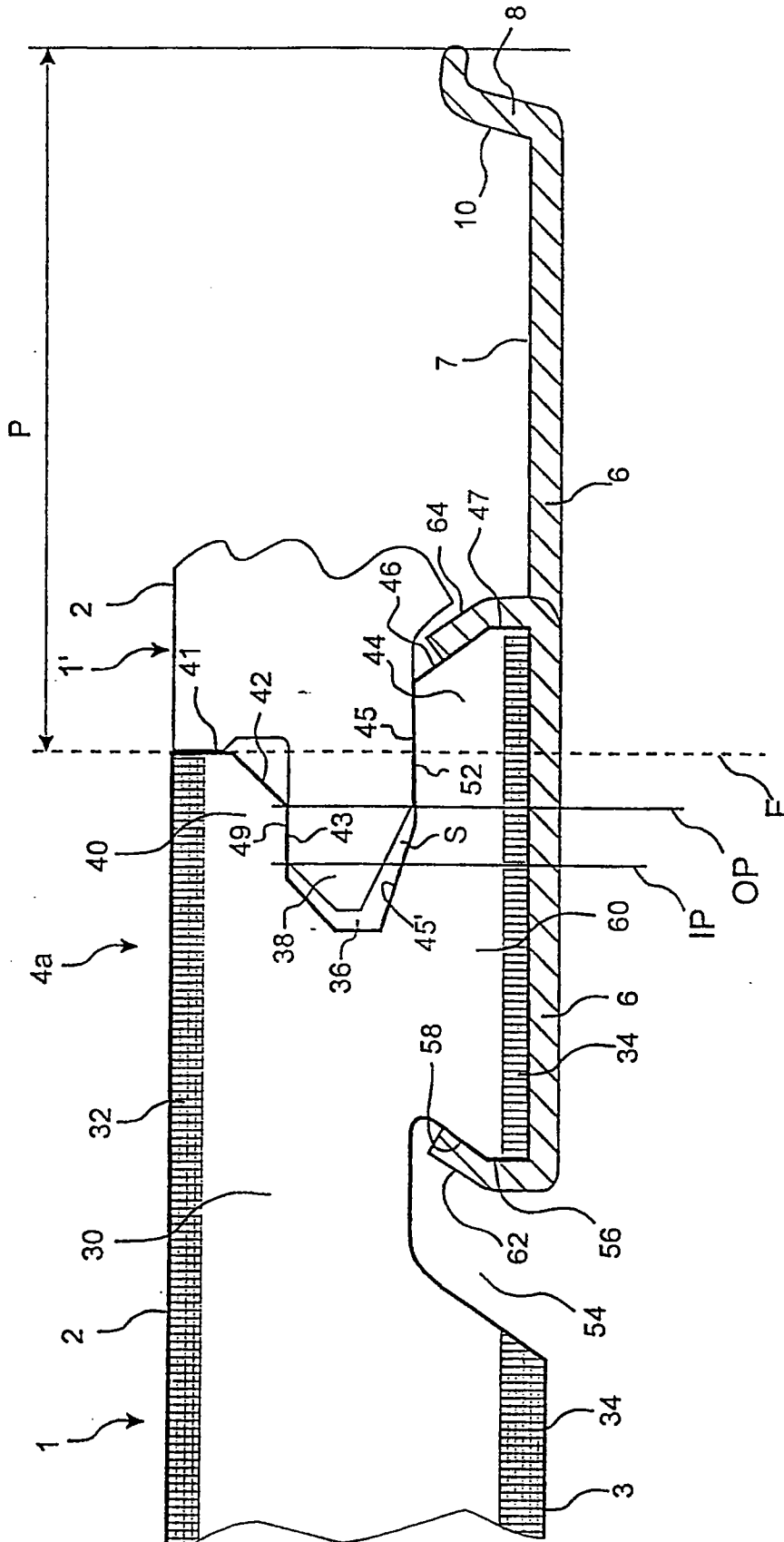

Fig. 6b

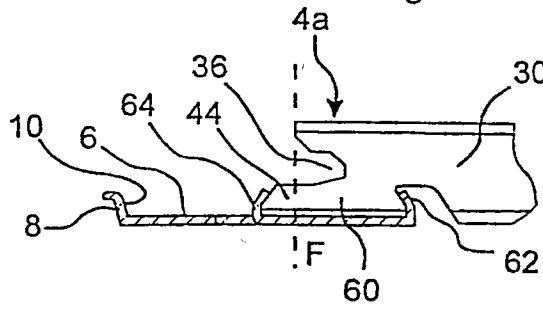

Fig. 5

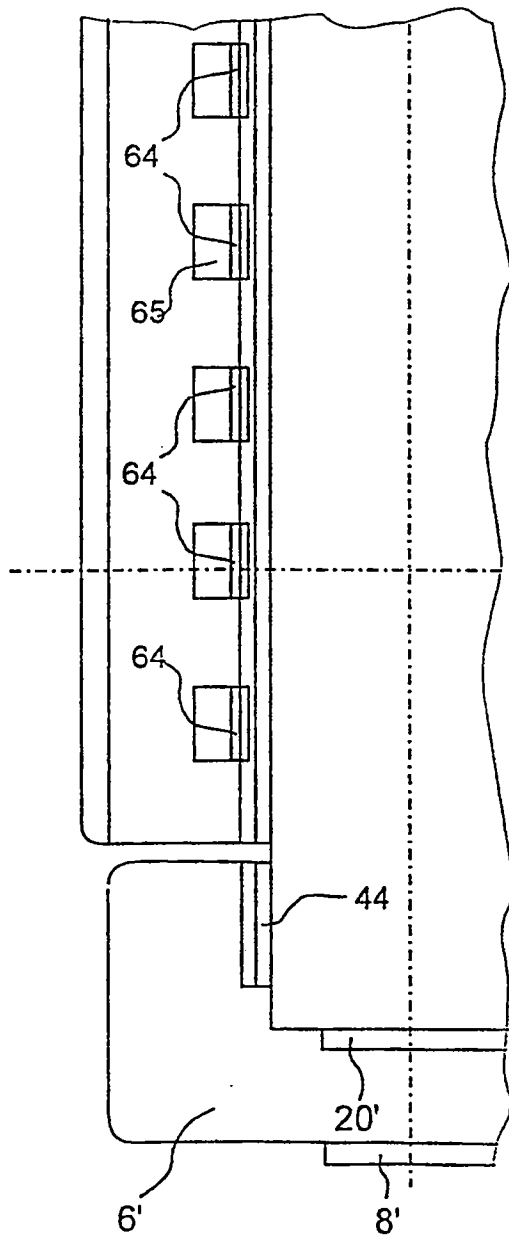
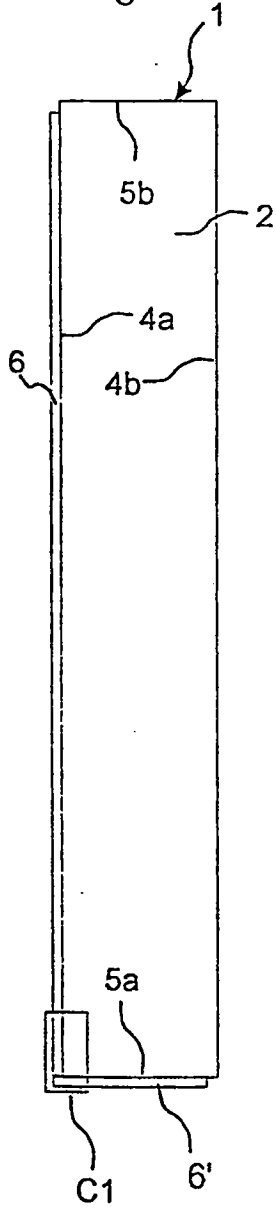

Fig. 6a

Fig. 6c

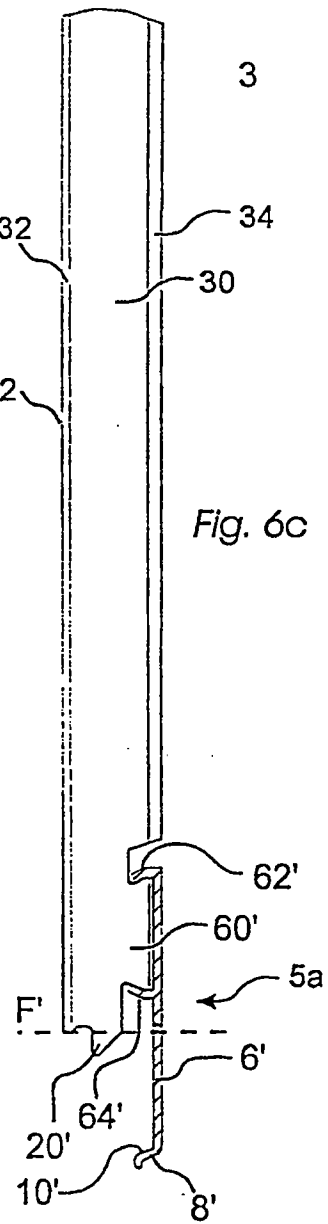

Fig. 7a

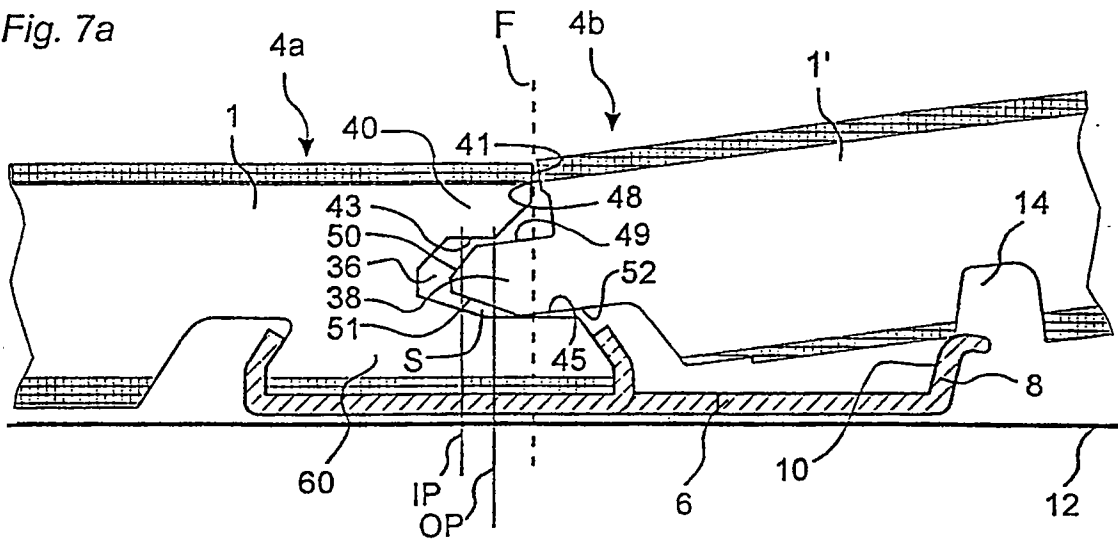

Fig. 7b

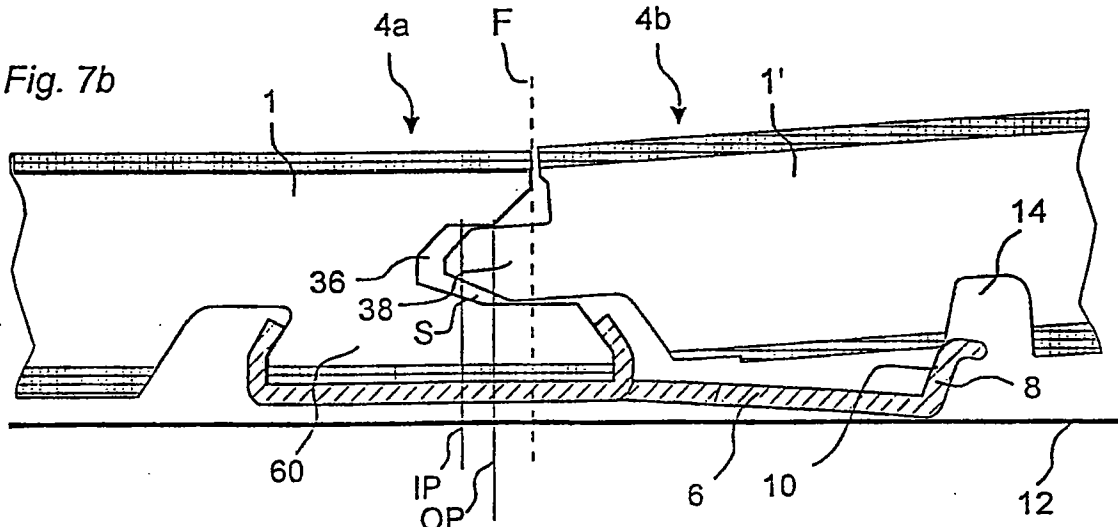

Fig. 7c

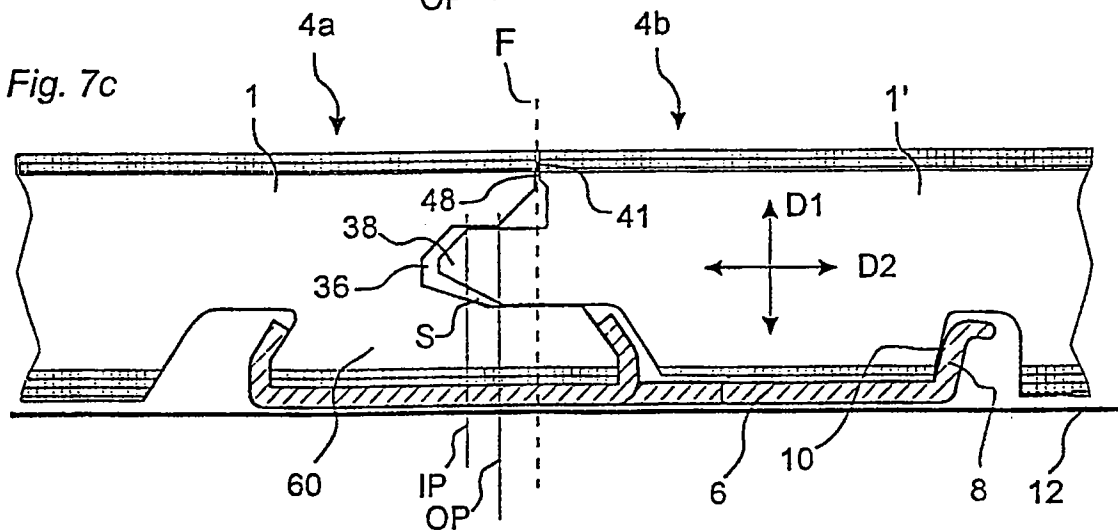

Fig. 8a

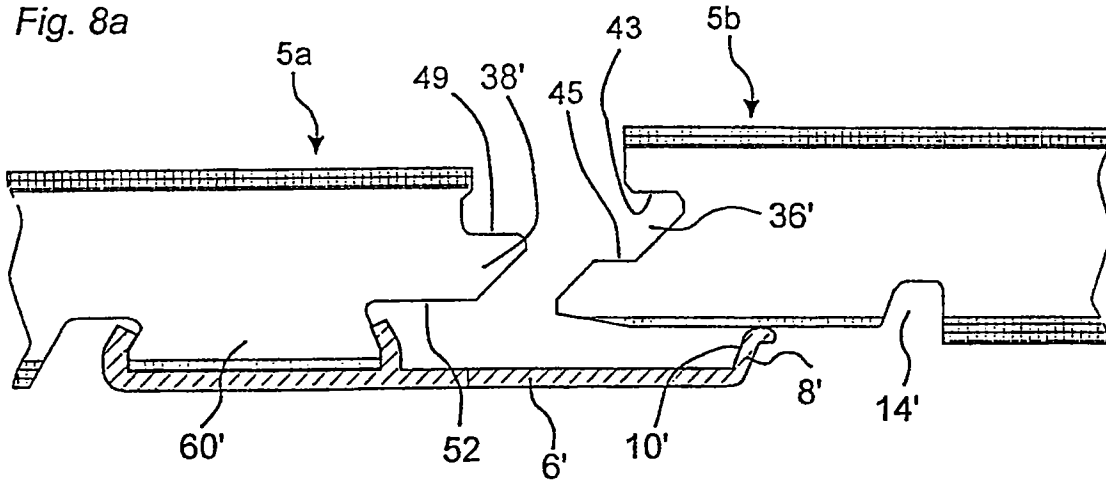

Fig. 8b

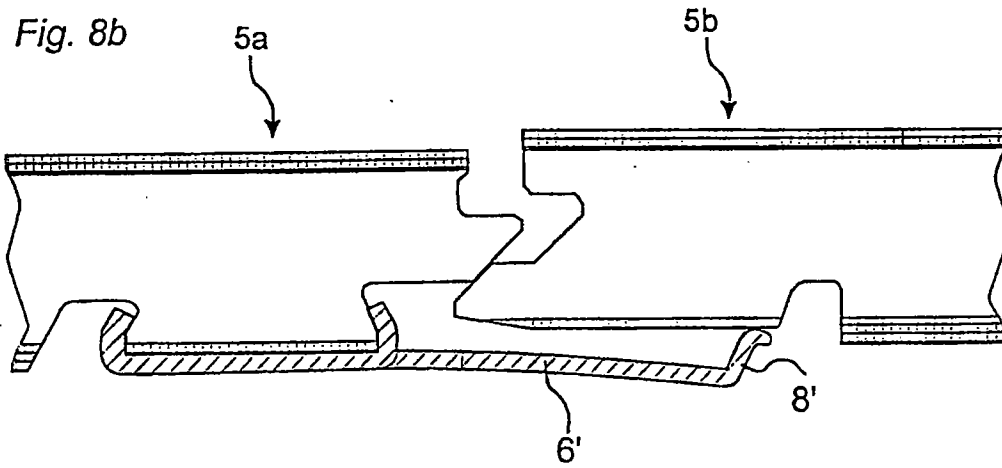

Fig. 8c

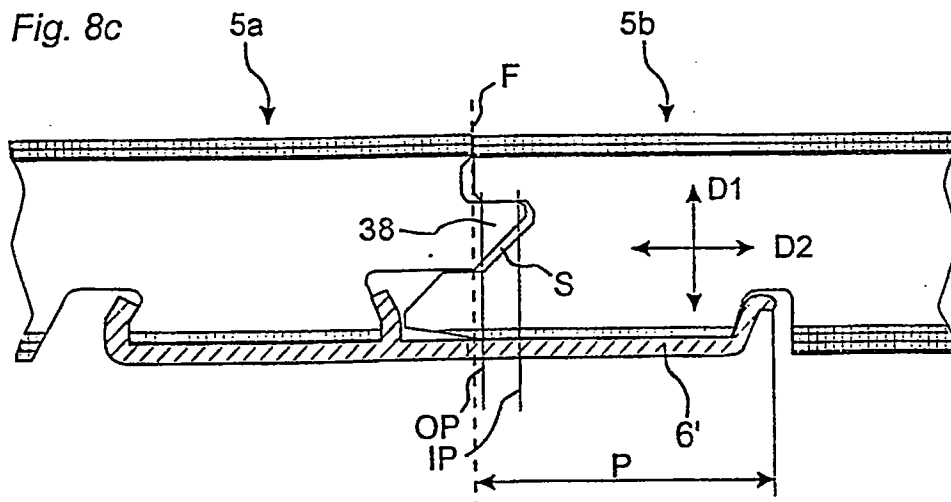

Fig. 9

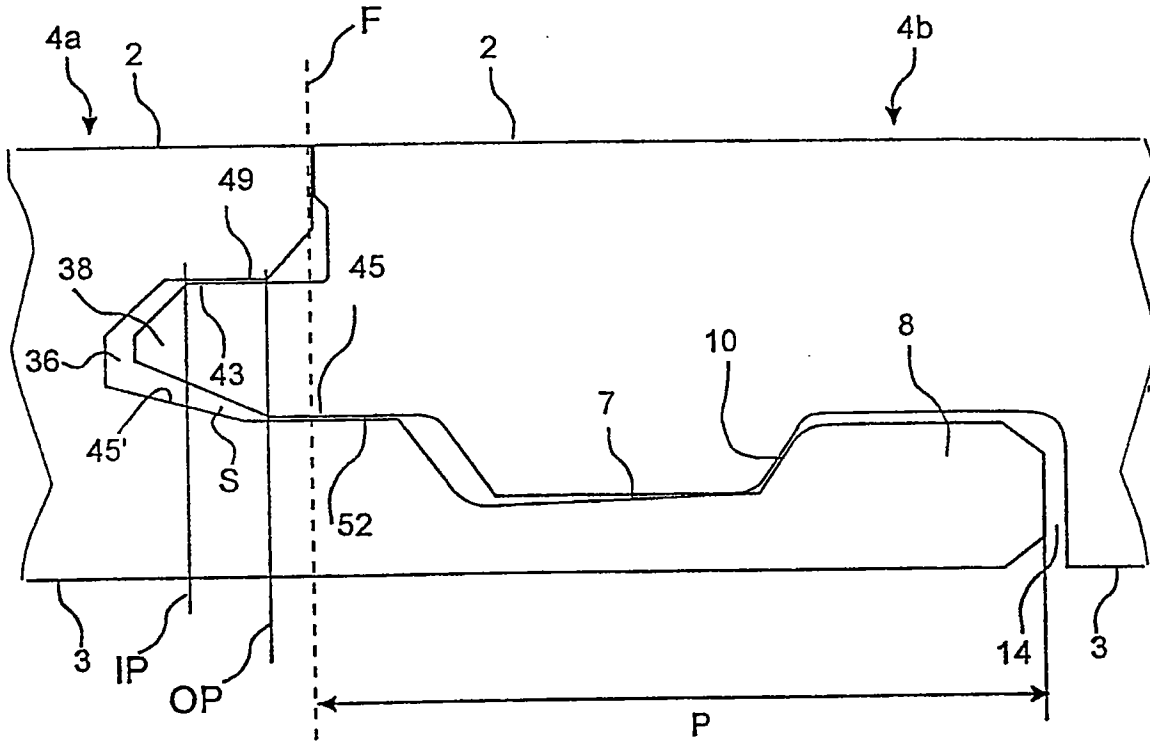

Fig. 11

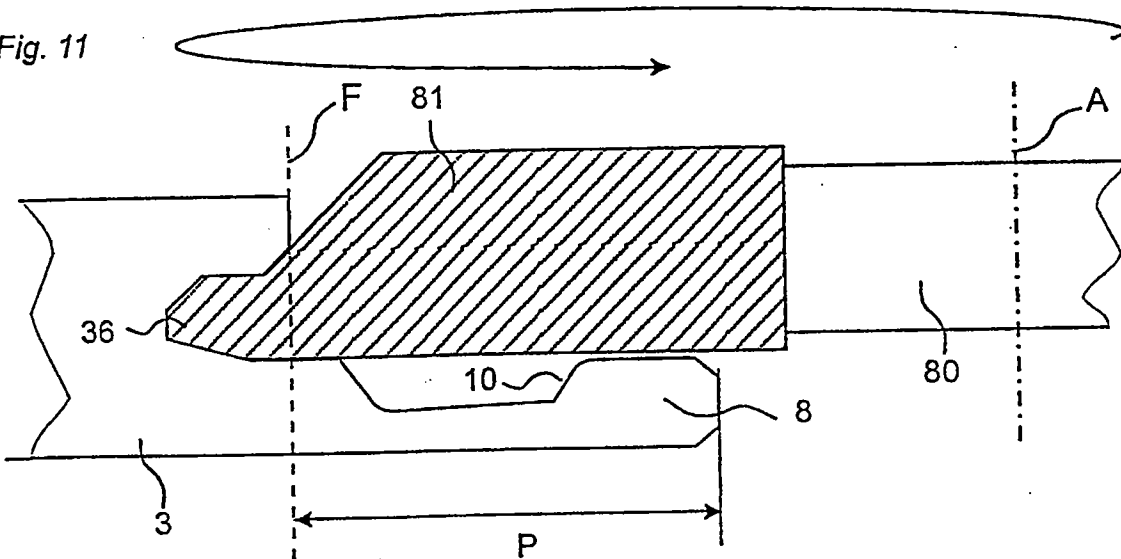

Fig. 10a

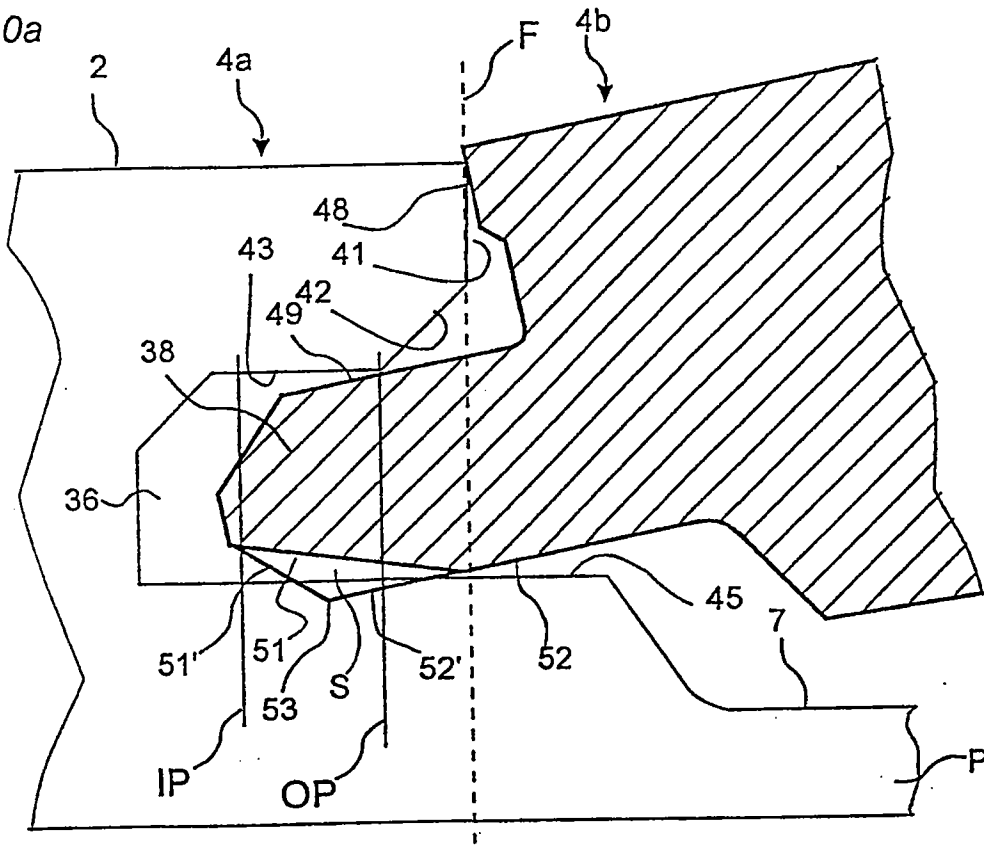
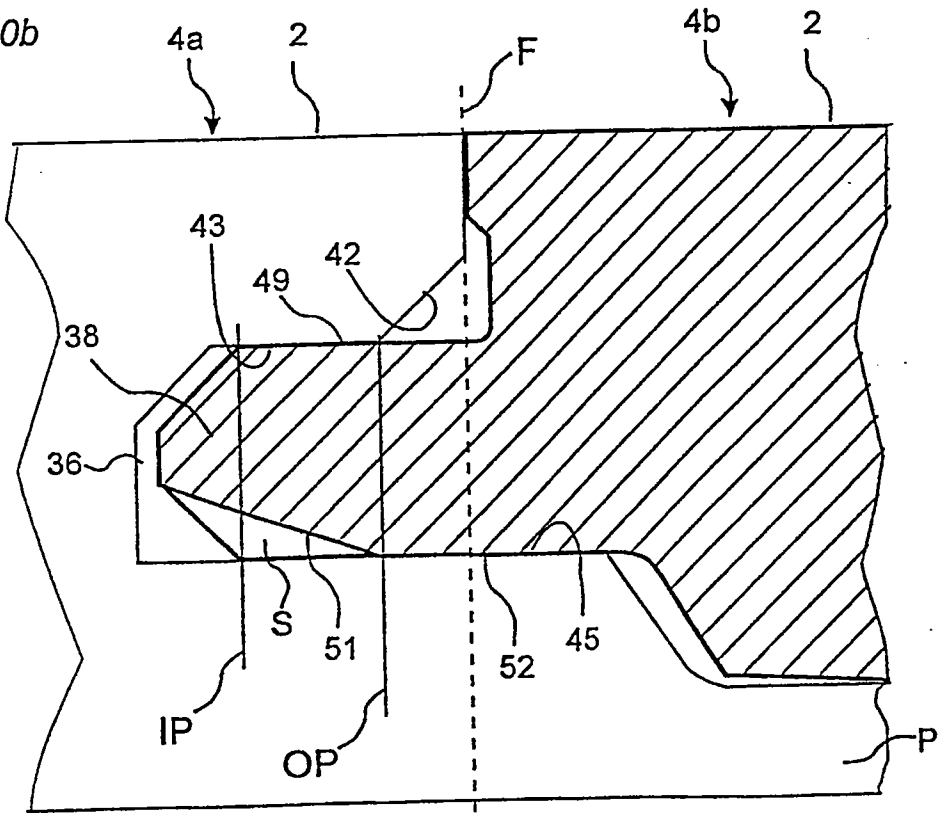

Fig. 10b



INTERNATIONAL SEARCH REPORT

International application No.

PCT/SE 99/00933

A. CLASSIFICATION OF SUBJECT MATTER

IPC6: E04F 15/04

According to International Patent Classification (IPC) or to both national classification and IPC

B. FIELDS SEARCHED

Minimum documentation searched (classification system followed by classification symbols)

IPC6: E04F

Documentation searched other than minimum documentation to the extent that such documents are included in the fields searched

SE,DK,FI,NO classes as above

Electronic data base consulted during the international search (name of data base and, where practicable, search terms used)

C. DOCUMENTS CONSIDERED TO BE RELEVANT

Category*	Citation of document, with indication, where appropriate, of the relevant passages	Relevant to claim No.
A	WO 9426999 A1 (VÄLINGE ALUMINIUM AB), 24 November 1994 (24.11.94), figures 2a-2c, 3a-3c, abstract --	1-19
A	WO 9627719 A1 (PERSTORP FLOORING AB), 12 Sept 1996 (12.09.96), figure 3, abstract --	1-19
A	WO 9627721 A1 (PERSTORP FLOORING AB), 12 Sept 1996 (12.09.96), figure 3, abstract --	1-19
A	WO 9747834 A1 (UNILIN BEHEER B.V.), 18 December 1997 (18.12.97), abstract --	1-19

 Further documents are listed in the continuation of Box C. See patent family annex.

* Special categories of cited documents:

"A" document defining the general state of the art which is not considered to be of particular relevance

"E" earlier document but published on or after the international filing date

"I" document which may throw doubts on priority claim(s) or which is cited to establish the publication date of another citation or other special reason (as specified)

"O" document referring to an oral disclosure, use, exhibition or other means

"P" document published prior to the international filing date but later than the priority date claimed

"T" later document published after the international filing date or priority date and not in conflict with the application but cited to understand the principle or theory underlying the invention

"X" document of particular relevance: the claimed invention cannot be considered novel or cannot be considered to involve an inventive step when the document is taken alone

"Y" document of particular relevance: the claimed invention cannot be considered to involve an inventive step when the document is combined with one or more other such documents, such combination being obvious to a person skilled in the art

"&" document member of the same patent family

Date of the actual completion of the international search

23 Sept 1999

Date of mailing of the international search report

11-10-1999

Name and mailing address of the ISA
Swedish Patent Office

Authorized officer

INTERNATIONAL SEARCH REPORT

International application No.
PCT/SE 99/00933

C (Continuation). DOCUMENTS CONSIDERED TO BE RELEVANT		
Category*	Citation of document, with indication, where appropriate, of the relevant passages	Relevant to claim No.
A	GB 2256023 A (MAGNET HOLDINGS LIMITED), 25 November 1992 (25.11.92) ----- -----	1-19

INTERNATIONAL SEARCH REPORT
Information on patent family members

30/08/99

International application No.

PCT/SE 99/00933

Patent document cited in search report	Publication date	Patent family member(s)	Publication date
WO 9426999 A1	24/11/94	AT 171238 T	15/10/98
		AU 671919 B	12/09/96
		AU 6763094 A	12/12/94
		BG 61457 B	29/08/97
		BG 100126 A	28/06/96
		BR 9406718 A	06/02/96
		CA 2150384 A	24/11/94
		CN 1122623 A	15/05/96
		CZ 9502852 A	15/05/96
		DE 69413391 D,T	04/02/99
		EP 0698162 A,B	28/02/96
		SE 0698162 T3	
		EP 0855482 A	29/07/98
		EP 0877130 A	11/11/98
		ES 2122280 T	16/12/98
		FI 951211 A	15/03/95
		HU 75843 A	28/05/97
		HU 214470 B	30/03/98
		HU 9503216 D	00/00/00
		JP 8510022 T	22/10/96
		LV 11491 A,B	20/08/96
		NO 305614 B	28/06/99
		NO 950790 A	22/05/95
		NO 986137 A	22/05/95
		NO 993136 A	24/06/99
		NZ 266232 A	26/11/96
		PL 311568 A	19/02/96
		SE 501014 C	17/10/94
		SE 9301595 A	17/10/94
		SG 47518 A	17/04/98
		SK 141195 A	06/11/96
		US 5706621 A	13/01/98
		US 5860267 A	19/01/99
WO 9627719 A1	12/09/96	AU 2941495 A	25/01/96
		AU 5017696 A	23/09/96
		EP 0730435 A	11/09/96
		JP 9502639 T	18/03/97
		SE 502994 C,E	04/03/96
		SE 9500809 A	04/03/96
		US 5779477 A	14/07/98
WO 9627721 A1	12/09/96	AU 4960096 A	23/09/96
		BR 9607272 A	23/06/98
		CA 2213757 A	12/09/96
		CN 1177390 A	25/03/98
		EP 0768929 A,B	23/04/97
		EP 0813641 A	29/12/97
		JP 10502303 T	03/03/98
		JP 11501377 T	02/02/99
		NO 974110 A	06/11/97
		SE 9500810 D	00/00/00
		US 5897272 A	27/04/99

INTERNATIONAL SEARCH REPORT
Information on patent family members

30/08/99

International application No.

PCT/SE 99/00933

Patent document cited in search report	Publication date	Patent family member(s)	Publication date
WO 9747834 A1	18/12/97	AU 3256997 A	07/01/98
		BE 1010339 A	02/06/98
		BE 1010487 A	06/10/98
		BG 102230 A	30/09/98
		BR 9702325 A	09/03/99
		CA 2226286 A	18/12/97
		CN 1195386 A	07/10/98
		CZ 9800391 A	12/08/98
		DE 29710175 U	14/08/97
		EP 0843763 A	27/05/98
		NO 980569 A	10/02/98
		PL 324923 A	22/06/98
		SI 9720009 A	31/08/98
		SK 16398 A	09/09/98
<hr/>			
GB 2256023 A	25/11/92	NONE	
<hr/>			